

---

# Heating control

---

Maximising comfort, minimising energy consumption



---

# Preface

---

Reducing energy use makes perfect business sense; it saves money, enhances corporate reputation and helps everyone in the fight against climate change.

The Carbon Trust provides simple, effective advice to help businesses take action to reduce carbon emissions, and the easiest way to do this is to use energy more efficiently.

This technology guide covers heating control. It introduces the main energy saving opportunities for existing systems and explains how upgrading controls can cut energy consumption and save money.

# Introduction

Heating can account for as much as 60% of total energy use, yet a large proportion of the energy consumed by heating is likely to be wasted due to incorrect control settings. In fact, it is possible to cut heating costs by up to 30% by implementing some simple energy saving measures.

Heating controls are required to ensure that heating systems operate safely and efficiently. They also protect buildings, heating plants and other machinery from frost and condensation damage.

The essence of good heating control is to operate a heating system only when it is required and to the minimum acceptable temperature. There are a variety of controls to help achieve this and the main types affect time, temperature and the operation of the boiler.

## Did you know?

Overheating is a sign of poor control. It wastes money and energy and creates uncomfortable working conditions.

By controlling your heating better, you will not only be saving money, but also improving overall comfort levels for staff.

This guide will help the reader:

- Understand their existing controls and ensure controls are set up correctly
- Choose the best types of control, particularly when considering upgrading a heating system.

Heating controls in business premises work on the same principle as those in the home, but usually on a much bigger scale. However, larger buildings are often more difficult to control because:

- It takes longer for the building to heat up to the required temperature
- There is a bigger concentration and variety of heat loads and gains (for example, staff and equipment)
- There are usually greater variations in usage patterns throughout the working week.

Time and temperature control need to be carefully considered for any commercial building. This publication focuses on the control of 'wet' systems which provide heat using a boiler.

## Remember

The solutions outlined in this guide do not just apply to refurbishment and new build; these are also issues for businesses that are renting or moving premises. Some managers insist on a rent review to discuss these issues with the landlord. After all, your business bears the costs of your landlord's inefficient equipment.

Your landlord can also help you locate and work your controls. If any controls are labelled 'do not touch', explore why. There may be a valid reason but it could just be for the convenience of the maintenance technician.

Wet systems are the most commonly found systems in the UK and are used in the majority of buildings even when other systems are in use. Other systems tend to be more straightforward and come with their own controls. However, the principles in this guide will apply to most kinds of heating system.

\* For an explanation of different types of system, see page 6.

# Energy consumption

Poor control of heating and hot water services is the cause of excessive energy consumption in many small commercial and multi-residential buildings. In premises with well-controlled systems, heating fuel consumption is typically 15-30% lower. Good control not only saves energy, but also maintains a consistently comfortable environment for building occupants, as well as reducing plant maintenance costs.

A well-controlled system will ensure that the boiler or heater does not operate unless there is a demand; it only provides heat when and where it is required in order to achieve desired temperatures. Therefore, the selection of appropriate controls plays a key part in the overall running costs of a heating or hot water system.

The cost benefits of controls should not be underestimated. Upgrading controls on older heating systems, for example, can save over 15% on energy bills when fitting a full set of controls to a system which previously had none.

Controls can impact on energy use in two different ways: they reduce heating requirements and increase heating and hot water system efficiency. Reducing heating requirements has by far the biggest impact on energy consumption. This can be achieved by reducing the heating 'on' time and set temperature so that they better match occupant requirements and times of use. It is important to ensure that suitable controls are specified which allow for adjustments according to energy demand.

The chart below shows the typical proportion of energy use that heating accounts for in certain sectors.

*Chart 1 Heating as a proportion of energy use in building types*

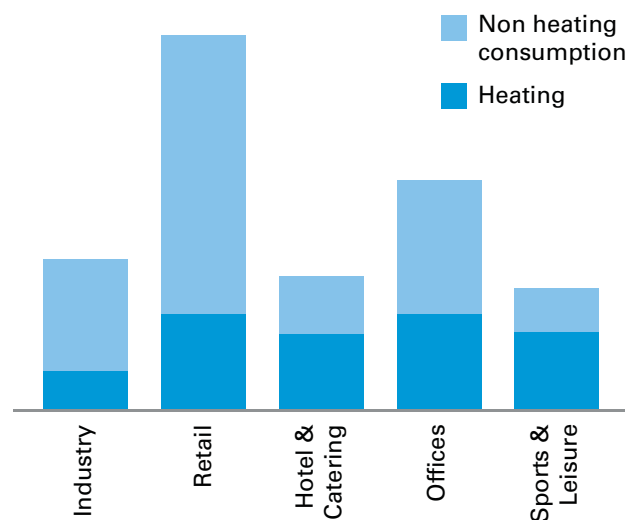

## Did you know?

Heating typically accounts for around half of the energy used in offices.

## Recommended temperatures

The table on the right shows the recommended temperatures for particular buildings, activities and processes. Refer to [page 10](#) for regulations on minimum temperature for types of work.

Sector	Building/room type	Temperature (°C)
Offices/service companies	Computer rooms	19-21
	Banks, building societies; post offices	19-21
	Offices	21-23
Hospitality	Restaurants/dining rooms	22-24
	Bars	20-22
	Hotels	19-21
Schools/further and higher education	Educational buildings	19-21
Industrial/factories	Heavy work	11-14
	Light work	16-19
	Sedentary work	19-21
Hospitals and healthcare	Bedheads/wards	22-24
	Circulation spaces/wards	19-24
	Consulting/treatment rooms	22-24
	Nurses' stations	19-22
	Operating theatres	17-19
Public buildings	General building areas	19-21
	Law courts	19-21
	Libraries	19-21
	Exhibition halls	19-21
	Laundries	16-19
	Churches	19-21
	Museums and art galleries	19-21
	Prisons	19-21
	Retail	Retail buildings
Sports and leisure	Changing rooms	20-25
	Sports halls	15
	Pool halls	28-30*

Source: Adapted from Environmental Design CIBSE Guide A, 2006

\*Depending on pool water temperature

# Technology overview

## Heating systems

Understanding the basics of a heating system is the first step to making it work efficiently.

A variety of heating systems are employed throughout the UK to provide space heating and hot water to buildings and industry. For some industrial processes, heating systems can be very complex but for the majority of buildings, heating is provided by one or a combination of the following three systems:

- **Wet systems** – these use water (or sometimes steam) to transfer heat from a source (such as a boiler) to a heat ‘emitter’ (typically a radiator, a fan coil heater or a convector)
- **Warm air systems** – these use warmed air to transfer heat from a heat source to the building (usually via air ducts although some warm air systems provide heat directly through stand-alone units)
- **Radiant systems** – these use infrared radiation to provide heat directly without the need for warmed air as a transfer medium (for example, gas fired radiant heaters and electric quartz lamps)

Each system differs in how it produces heat and the type of heat it provides. Although this guide discusses wet systems, the general principles are applicable to most types of heating system.

The information box on the next page gives a practical guide to identifying your heating system.

## Types of heating control

Heating control can be categorised into:

- Boiler (heating system) control
- Time control
- Temperature control.

The principal controllers for each of these are outlined below.

### Boiler control

The principal function of most boiler controls is to maintain the desired temperature of water that flows from the boiler. This is achieved by controlling the firing of the burner inside the boiler. At the most basic level, these controls simply turn the system on and off or provide a high or low setting. This is often the most that controls can do, however, there are still opportunities for energy saving.

### Firing control

The objective of boiler firing control is to regulate the burner to maintain the desired boiler flow temperature. Boiler firing controls are normally packaged with the boiler. For more details please refer to the Carbon Trust’s [How to Implement Oxygen Trim Control \(CTL147\)](#) guide.

### Sequence control

When a business has multiple boilers, sequence control ensures that only the boilers that are actually required to meet the demand are operating. This provides a more efficient operation of those boilers.

Other types of boiler control, including boiler inhibit controls and optimised start stop control, are discussed elsewhere in this guide. For more in-depth information on boiler controls for wet systems, please refer to the Carbon Trust’s Technology Overview on [Low temperature hot water boilers \(CTV008\)](#).

## Time control

Time controls are fundamental to any efficient heating system – they specify when the heating should come on and for how long. Set correctly, they ensure the system operates at the best times in terms of building occupancy and requirements. Most heating systems have some sort of time control and understanding how they work and how to set them up is essential in order to achieve significant cost savings.

“Lowering heating temperatures by just 1°C can save 8% on fuel consumption”

Time controls come in a variety of shapes and sizes, makes and models. They will often be located near the boiler or hot water storage. Below are some common types:

### 24-hour dial time switch

A typical 24-hour dial time switch has two switching circuits. There are usually two dials: the outer dial is of a higher resolution and shows the minutes past the hour that the heating is switched on and off. The inner dial shows just the hour.

### Old seven-day time switch

Typical, older seven-day time switches often have a small dial hidden behind the main dial allowing days of the week to be selected or omitted.

### New electronic time switches

More modern electronic time switches come in a variety of forms and can be set for each day of the week. These are well worth the effort of learning to programme as they provide excellent control.

## What kind of heating system do you have?

The following questions can help you identify the heating system in your building.

- Are there radiators? If so, the heating system also usually has a boiler, pumps and distribution pipework. This is known as a wet system.
- Is the circulating air warm? You will either have air handling units that deliver warm air through ducts (and possibly unheated or cooled air during the summer) or unit heaters that use fans to distribute warm air around the building. This is a warm air system.
- Do you only have electricity on your site? You may be using local electric heaters or a ventilation system that heats the air (both are expensive to run).
- Do your heaters get very hot and glow red? These are radiant heaters. They are good at creating comfortable conditions when internal air temperatures are low and are ideal for large areas with poor insulation or for providing local ‘spot heating’ in wider open spaces such as retail warehouses.
- Do you have discrete units pushing hot air into the space? These are quite common in industrial buildings.

## Temperature control

Temperature controls help heating systems to provide just the right temperatures to maintain comfort without wasting energy and money. Most heating systems will have some sort of temperature control. The two most basic and common kinds of building temperature control are wall thermostats and thermostatic radiator valves (TRVs).

### Wall thermostats

Wall thermostats (also called room thermostats) are commonly used for control of heating systems. Thermostats control the operation of the boiler and/or pump, switching it on or off when the space temperature limits are reached. It is common in small systems for the thermostat to control just the heating pump, however, greater energy savings can be achieved by switching the boiler as well as the pump.

A thermostat usually directly switches a heating system on and off and can be set and adjusted by the user. It has a typical switching differential between on and off of about 2.5°C.

A temperature sensor is the part of the thermostat that takes a reading of the temperature and feeds a signal back to a controller that then switches the heating on and off. The controller is usually located in the boiler or plant room and may not be easily set and adjusted by users. The accuracy of such a sensor is around  $\pm 0.5^\circ\text{C}$ .

### Thermostatic radiator valves (TRVs)

A TRV is a simple control valve with an air temperature sensor, used to control the heat output from the radiator by adjusting water flow. Correctly fitted and operated TRVs can provide very efficient control. In a large room with several radiators and a variety of activities and heat gains, control of individual radiators can provide the correct level of localised heating.

### Did you know?

It is commonly assumed that a room will heat up faster if the thermostat is switched to maximum. What happens in practice, however, is that the temperature increases at a standard rate but then overshoots, making it uncomfortable for the occupants and using more energy than necessary. Make sure that you set the thermostat only to the required temperature.

### Further information

To order a copy of [Low temperature hot water boilers \(CTV008\)](#) and other publications related to heating control, contact the Carbon Trust (details can be found inside the back cover).

## Commonly found controls

Use the table on the right to help identify the devices your system uses.

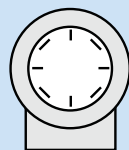

### Time switch

Simple time control of a system that will only switch one heating circuit. Most suitable for combination boilers. If installing a new time switch choose one that is easy to understand and use.

### Programmer

A programmer can switch two circuits separately (usually heating and hot water). There are three basic types:

- A mini-programmer allows space heating and hot water to be on together, or hot water alone, but not heating alone
- A standard programmer uses the same time settings for space heating and hot water
- A full programmer allows the time settings for space heating and hot water to be fully independent.

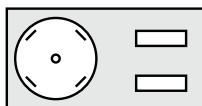

### Room thermostat

Simple room temperature control. Most modern room thermostats are able to smooth out the temperature cycle, so that on and off periods are not too long. Wireless units are now available that provide increased flexibility in positioning and eliminate visible wiring.

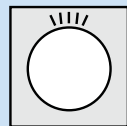

### Programmable room thermostat

Allows different temperatures to be set for different periods in the day or week. Provides a better match to the business working pattern than the more simple time switches, for example. This is important if occupancy is varied over the day or week. These can also provide a 'night setback feature' where a minimum temperature can be maintained at night. Many are battery operated and can replace a conventional thermostat without the need for additional cabling. Many also allow time control of hot water.

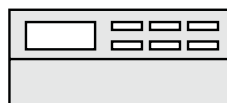

## Workplace (Health, Safety and Welfare) Regulations 1992

Appropriate minimum temperatures must be maintained in the workplace for the comfort of employees. 16°C is suggested as reasonable for sedentary work and 13°C for manual work. Factors such as humidity, ventilation and thermometer positions should also be taken into account.

However, many workers will prefer a temperature higher than the regulation standard, so see page 5 for the CIBSE recommended temperatures for certain activities.

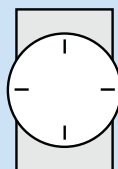

### Cylinder thermostat

Simple control of stored hot water temperature, usually strapped to the side of the hot water cylinder. It is commonly used with a motorised valve to provide close control of water temperature.

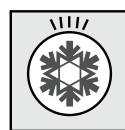

### Frost thermostat

Simple override control used to avoid frost damage to a building and/or boiler and system. A frost air thermostat should be fitted in a suitable place inside the building so that a minimum temperature is always maintained.

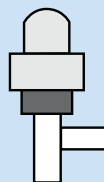

### Thermostatic radiator valve

Used to limit temperatures in individual rooms and so reduce energy consumption. Provides an upper limit to room temperatures and so can usefully prevent overheating due to solar and incidental gains from equipment.

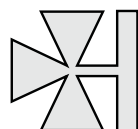

### Motorised valve

Used to control water flow from boiler to heating and hot water circuits. Two-port valves can also be used to provide zone control, such as lower temperatures in unoccupied areas or different heating times. Three-port valves are used with controls such as weather compensators.

# Using existing controls

## Making use of existing heating system controls

### Turn off unnecessary boilers and reduce costs by 5%

In multi-boiler installations (that is, more than one boiler operating together), it may be possible to turn off boilers which are not needed during milder weather. Multi-boiler installations are designed to cope with the highest level of heat demand – usually during winter – so running the full system all year round simply wastes money. Consult a qualified heating technician to discuss the range of options available.

### Constantly review your controls

Poorly maintained controls gradually deteriorate, which will affect comfort conditions and energy efficiency levels. Similarly, permanently overridden controls or failure to adjust settings when building usage or occupation patterns change will have the same effects.

### Did you know?

Heating costs can increase by 15% or more if boilers are poorly operated or maintained.

## Making use of existing time controls

### Check time controls are accurate

Ask:

- Are they displaying the correct time and date?
- Are they adjusted for daylight savings?
- Are they set for the right season?

### Check that controls match working hours

Adjust controls if necessary to ensure heating only operates when required, that is, to match the normal working day. Avoid running heating overnight, at weekends or in empty rooms. It may be possible to shut down the heating an hour before most people have left the building. This can reduce costs without affecting comfort levels.

The graph on the right shows that a great deal of energy can be saved by switching off heating overnight. The heating is set to switch off automatically at the end of the working day, and the building cools overnight when no one is there. The heating is set to come on in time to reach the desired temperature at the start of the work day.

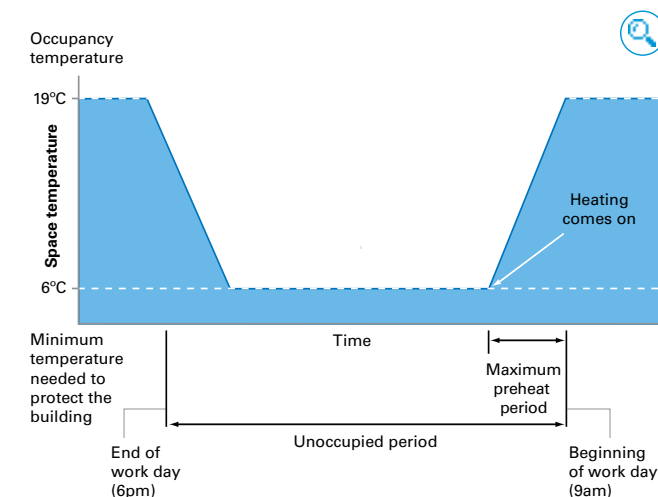

Find the latest start and earliest end times to allow the building to reach and maintain the right temperature when it is occupied. This can be achieved by making slight adjustments to switch on/off times. Repeat until temperatures are not quite reached by the occupancy time and then adjust back to the previous setting to give the correct warm-up time. This 'optimum time' will vary with the season and may need occasional adjustment.

This can be achieved automatically with an optimum start controller (see [page 18](#)).

## Making use of existing temperature controls

### Fit thermostats in the right place

Thermostats should not be influenced by draughts or heat sources such as sunlight, radiators or office equipment. These factors create a 'false local temperature' and may result in heating systems over or under heating a building. Thermostats should be placed in a north-facing room, approximately half way up the wall if possible. This helps to provide a more representative temperature.

### Check the temperatures

Thermostats should be regularly checked to ensure that they are working correctly. Some businesses use a separate room thermometer to double-check that the thermostats are turning the heating on when required. Heating should only be on if the temperature drops

below the recommended minimum (see [page 5](#)). If heating is on above these temperatures, check thermostats and adjust accordingly. If they are already set correctly and the heating is still on, ask a qualified heating technician to check or replace them. They may be faulty or badly calibrated.

### Do not let heating and cooling operate at the same time

Set controls to give a wide gap between the temperatures at which heating and cooling systems cut in. Set a gap between of around 4 – 5 °C between the heating and cooling thermostat set points to create a comfortable 'dead band'. This will help to keep occupants happy and increase cost savings. Unless this is implemented, both systems may operate simultaneously, wasting energy and money.

### Ideal thermostat location to accurately reflect genuine room temperature

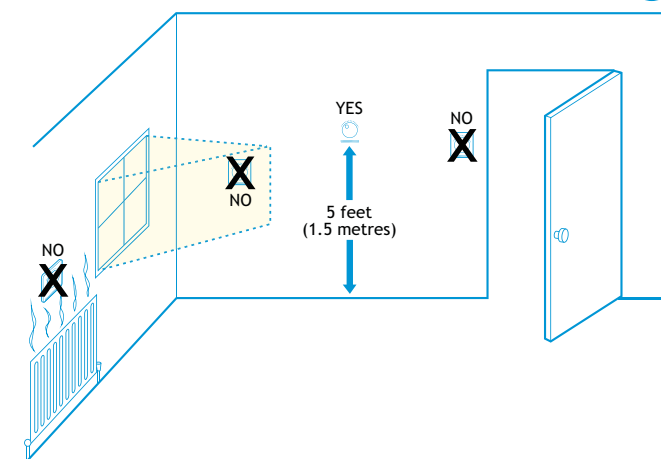

### Diagram of 'dead band' control indicating recommended temperatures

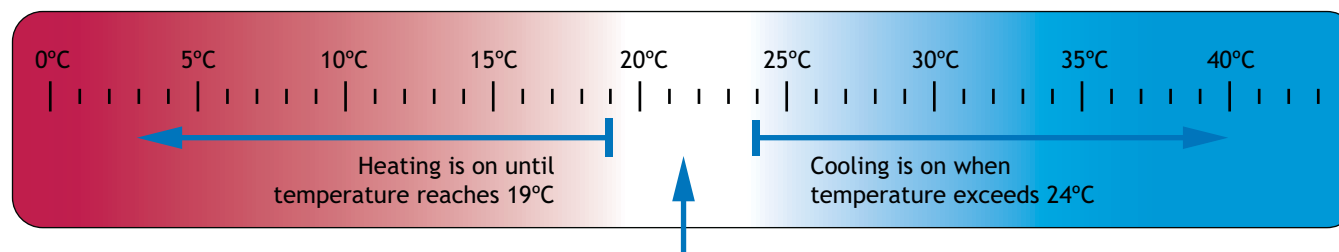

Heating and Cooling both off between 19°C and 24°C – a 'dead band' of 5 degrees

### Top tip

Don't know how to operate your controls? Your heating or maintenance technician should be able to help. Or, if you have an electronic time switch, make a note of the make and model and look on the internet for the supplier's website. They often have PDF versions of instructions available to download. Make notes on how to change times and days and display them in a prominent place.

## Getting the best from TRVs

Thermostatic radiator valves (TRVs) can be an efficient addition to many wet heating systems, but they need to be managed well to achieve the highest savings:

- Disable or remove any TRVs on radiators located near room thermostats as they may interfere with the correct sensing of room temperatures and affect the whole building
- Set TRVs lower (at 2-3) in unoccupied areas or those prone to overheating
- Install tamperproof TRVs which lock at a fixed setting to prevent staff using them as on/off switches.

### Top tip

Test TRVs annually by turning them up or down to check they provide a corresponding change in temperature in the radiator (bearing in mind the room temperature at the time). Make sure you remember to reset them after the test.

If in doubt, seek professional help.

## Maintain the correct control settings

Staff may have adjusted controls for temporary reasons, but forgotten to reset them. Regularly check that heating controls are set to match the needs of the staff – including everything from daily work patterns to seasons.

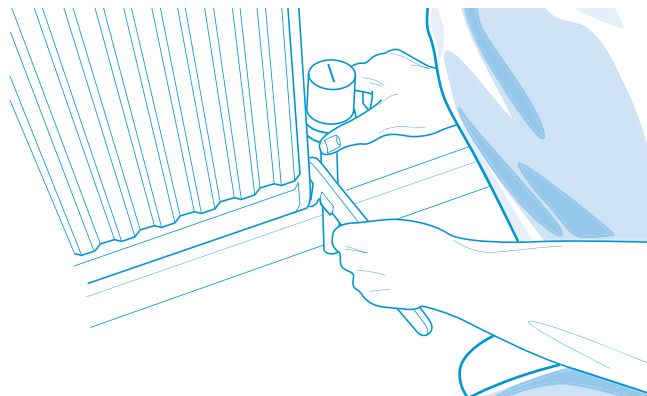

## Fabric and frost protection

Heating controls should protect the building, its contents, plant and pipework from frost and condensation damage. They should automatically switch on heating when the space, external air or return water temperatures fall to pre-set minimum levels (usually below 5-10°C, depending on individual circumstances).

A separate thermostat may need to be fitted to some simple controls. Frost protection space sensors or thermostats should typically be installed in the most vulnerable parts of the building.

## How do you control your heating system?

Always keep a copy of the manufacturer's instructions and ask the supplier/contractor to:

- Show how the time and day controls are set
- Show how to check for correct operation if you have advanced controls like weather compensation or optimum start controls (see [pages 18 and 19](#))
- Explain how to set summer hot water only
- Demonstrate adjustment of space temperature controls and explain their function
- Explain the layout of the heating zones and the advantages of maintaining zone integrity by closing interior doors (see [page 16](#))
- Stress the energy saving features of the control routines applied
- Put all this information into the Building Log book if you have one. If not, it is a good idea to start one. Find out more about Building Log books by contacting the Carbon Trust.

# Upgrading existing systems

Upgrading heating system or boiler controls can save significant amounts of energy and increase the life of your heating plant. Do not miss the opportunity to make big, long-term savings when refurbishing – choose a heating system that provides appropriate control. Consider the following options to help reduce your costs and energy consumption.

## Modulating boilers

Modulating boilers are designed to provide an amount of heat to match the requirements of the heating system at a particular time. Rather than using a simple on/off burner, modulating boilers vary their rate of fuel input to control their heat output. This results in better efficiency and greater savings.

## Multiple boilers

A series of smaller boilers that cater for the heating demand can be more efficient than running a single large boiler. This is achieved by dividing the overall heating load among two or more independently controlled boilers and then only operating the boiler(s) necessary to meet the load at a given time. Multiple boilers are usually set up with an intelligent controller that determines the number of boilers that need to be firing to maintain the correct temperatures. They are easy to maintain and can provide substantial savings as well as lower the risks of a single breakdown disrupting the heating supply.

## Boiler sequence control

If the system comprises two or more gas or oil-fired boilers, a 'sequence control' should be installed. This ensures that the number of boilers online is matched to the heating demand, thereby maximising overall efficiency. Good sequence control also avoids short cycling of burner operation, where the boiler keeps firing to top up the system. Rotation of boiler order evens out wear, which can prolong system life and can be carried out manually or automatically.

Where there are both condensing and ordinary boilers installed, the condensing boiler should always take the lead. Similarly, if there is a combined heat and power (CHP) unit, this should be the lead heat source and be sized for the base load.

Good sequence control could save 5-10% of the overall energy consumption of the boiler plant. For more information see the Carbon Trust's [How to Implement Boiler Sequencing Control CTL144](#) guide.

## An illustration of boiler sequence control

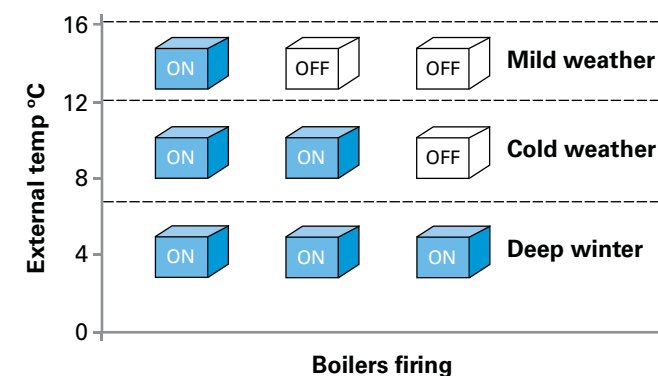

## Did you know?

Inadequate or incorrect application of boiler control can easily add 15-30% to fuel consumption compared with a well-controlled system.

## Boiler inhibit controls

Boilers can continue to fire even when the room thermostat or heating time switch shuts off the pump. This wastes money during periods when there is no demand for heating.

Boiler inhibit controls ensure that the boiler does not fire when there is no need for heating. This is done by fixing a standard interlock or specialised integrated controller. It is possible to arrange for the wiring to be altered so that the thermostat and heating time switches shut off both the circulating pump and the boiler(s). For regular boiler systems, the interlock is usually arranged so that the room or cylinder thermostat switches the power supply to the boiler (and sometimes the pump) through the motorised valve 'end' switches. For combination boilers, interlock is usually achieved by using a room thermostat. Consult a heating technician to discuss the options available.

### An illustration of boiler inhibit controls

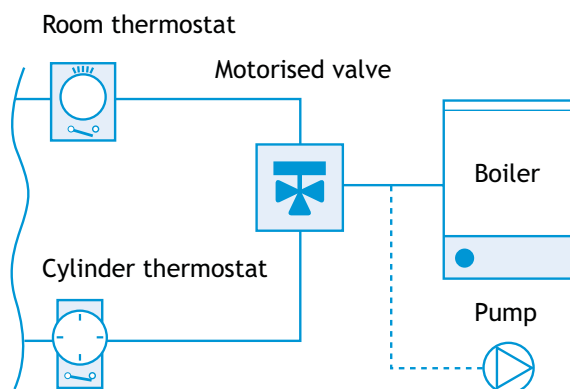

## Consider zoning to match building occupancy and reduce operating costs

Buildings frequently have problematic areas with different time and temperature requirements, where only one overall heating or cooling control system exists. In this instance, consider zoning to increase comfort levels and energy savings (see zoning information box on [page 16](#)).

## Operational issues with advanced controls

As a general rule, it is best not to complicate a system unnecessarily. However, the more complex systems give the greatest potential for energy savings provided they are correctly applied and maintained. It is essential to ensure that controls do not interfere or conflict with each other.

Before deciding on the appropriate level of complexity required it is worth considering the following points:

- The size and complexity of the building**  
 For small individual buildings or those with a uniform pattern of occupancy, pre-set or self-adaptive controls with an override option for out-of-hours working should provide an appropriate level of comfort and energy savings over a poorly controlled system. Bigger buildings with more varied requirements are likely to benefit from a more complex control system.

- Existing equipment**

The existing heating or ventilation equipment may be unable to respond effectively to the level of control proposed. It may be necessary to invest in new equipment before savings can be realised through sophisticated controls. Similarly, it is important to ensure that the building is able to be zoned as necessary.

- Staff available**

A complex control system needs suitably trained people with the time available to manage it and use the data produced. There must be staff resource to ensure that controls are calibrated correctly, tested and working well, as controls will not continue to make savings on their own. If no one is available, it is unlikely that the potential savings of the control system will be achieved.

A high proportion of faults which occur with building control systems are due to poor design, inadequate specification or incorrect installation. It is vital that adequate finance and time are set aside to allow these areas to be covered in the detail required. For more guidance installing controls please refer to our [How to Implement a Building Energy Management Systems \(CTL149\)](#) guide.

## Zoning

Some areas in large buildings require different levels of heating. A solution to this is to create 'zones' in the building where separate time and temperature controls are installed for individual areas. Zoned areas will provide closer, more efficient heating control. This can improve local conditions – and save on costs.

Zoning should be considered when there are:

- Different occupancy patterns
- Different temperature requirements
- A number of floors (particularly where top floors are poorly insulated).

**Example 1:** South-facing rooms are subject to solar heat gains which may be sufficient to remove the need for mechanical heating. Solar heat gains might produce a situation where there is significant difference from one side of the building to the other, so a north and south zone might be set up where heating to the south side of the building could be shut off while the cooler north side of the building is still operating.

**Example 2:** Separate zones can be used to cater for different occupancy within a building – for example in offices within shops and storage areas. Rather than continually heating the whole building, it can be zoned so the shop space is heated during retail hours (e.g. 8am–4pm) whereas the office space is heated based on office hours (e.g. 9am–6pm).

Individual room by room control can be achieved using TRVs which create simple zones. An alternative method of zoning, appropriate to larger buildings, would be to install separate pumps and pipework to supply each zone. Motorised valves, zone temperature sensors and an appropriate control system would then be required to control the flow of heat into each zone.

Although zoning can involve a capital investment, costs can be recouped over time through savings. However, the most obvious improvement is increased staff comfort and productivity as local temperatures can be better controlled by the occupants. For more information please refer to the Carbon Trust's [How to Implement Heating Zone Controls CTL148](#) guide.

Enhanced capital allowances are available for heating control zoning technology that is on the energy technology list. See the Tax Incentives box on [page 22](#).

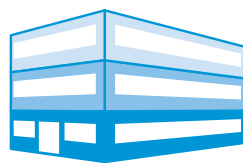

Multi-storey buildings can be zoned floor by floor

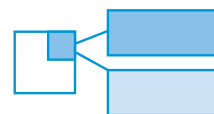

Multiple buildings served by the same boiler house can be zoned separately

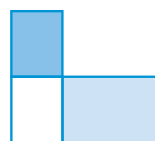

Most small commercial and multi-residential buildings will divide into at least two

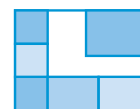

Multi-tenanted buildings provide an ideal opportunity to zone on the basis of tenants

## Warm air systems

The controls for warm air systems are simple compared with wet systems. Examples of warm air system controls are:

- Controls external to heater
  - time switch/programmer
  - room thermostat (standard or programmable)
- Controls integrated with heater
  - integrated programmer
  - room temperature sensor linked to heater firing and fan speed control.

## Best practice

Use warm air systems that incorporate integrated controls to ensure that the fan speed is varied to match the firing cycle of the burner. These controls reduce variations in room temperature so improving comfort, economy and noise levels.

## Upgrading time controls

Heating system control can be problematic with old, inefficient time controls. Implementing upgrades is well worthwhile as they can pay for themselves very quickly through energy and cost savings.

### Seven-day time switches

It should be possible to accurately programme the time setting on heating and ventilation systems to allow for weekends, early finishing and late evening work. Some older time switches cannot be programmed for different daily schedules (for example, earlier switch-off on Fridays, or part-day switching at weekends).

Programmable controls are available in daily (24 hours), weekday/weekend (five/two days), seven-day or 365-day versions. Install a modern seven-day electronic time switch to permit different settings for each day and control to the nearest 10 minutes or less.

The benefits of these are obvious – to be able to control when heating is on to such an extent means that unnecessary usage can be cut dramatically.

### Extension timers for greater flexibility

If out-of-hours heating is required occasionally throughout the whole building, consider fitting extension timers. This is a more efficient option than constantly reprogramming time switches. If only a part of the building is to be used, it may be more economical to provide local heating, and shut the main system down. Provide supplementary portable heaters where required but ensure that use is limited to approved periods only.

### Delayed off controls

These are particularly useful where heating needs to be extended beyond normal hours (for example, evening working in shops) or when occupancy in an area is unpredictable (such as in function rooms). Heating is switched on by the occupant but automatically switches off after a pre-set period.

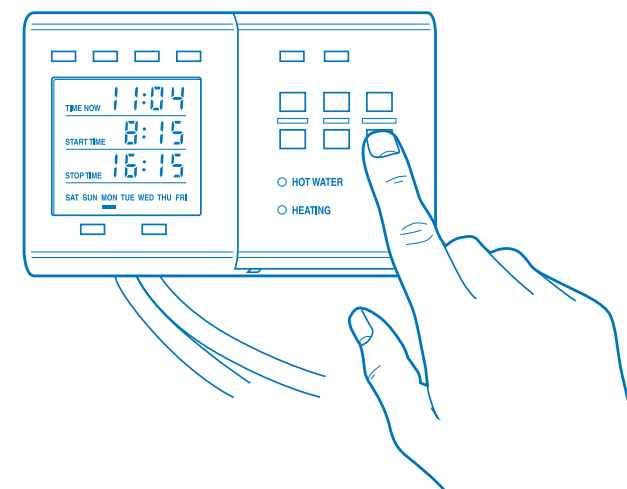

## Does the heating system incorporate an optimum start controller?

An optimum start controller is an advanced time control fitted to a heating system. It learns how quickly the building reaches the desired temperature and using an internal and/or external sensor, brings the heating on at the optimum time prior to building occupancy. This typically results in heating switching on later on mild days as shorter warm-up times are required. This can often provide a 10% efficiency improvement, even compared to a well-set seven-day time switch.

The chart (right) shows the saving potential of an optimum start controller.

When specifying an optimum start controller, remember:

- Most optimisers vary the heating start time on the basis of both internal space and external temperature readings. Generally, they are also self-adaptive in that they 'learn' the way that the building responds to the outside temperature and heating plant
- Simpler versions only take internal space temperature into account and are therefore less accurate
- Optimum stop control can also be used to switch the heating off as early as possible without compromising comfort conditions
- Most of these controllers will also provide day economy modes and automatic frost protection
- Savings are greatest in well-insulated buildings.

For more information please refer to the Carbon Trust's [How to Implement Optimum Start Controls CTL035](#) guide and our [Optimum Start Controls Animation](#).

## Saving potential of an optimum start controller.

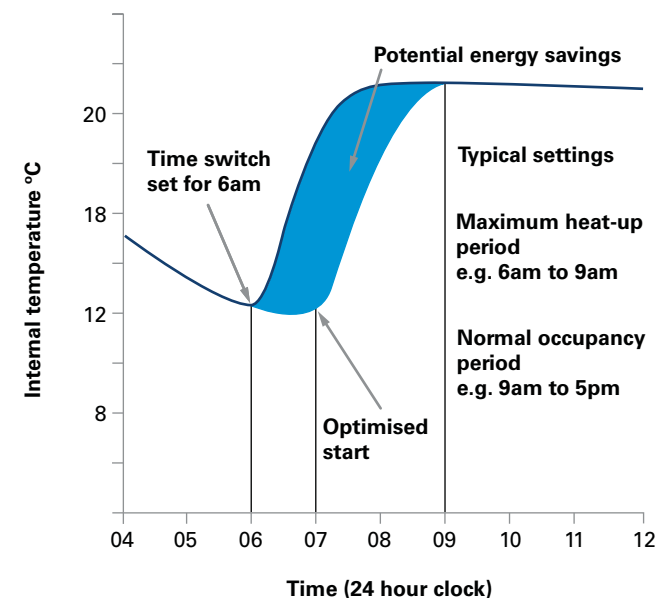

## Upgrading temperature controls

Out-of-date or very basic temperature controls can cause occupant discomfort and excessive energy consumption. Upgrading poor temperature controls will usually pay back very quickly while also improving staff comfort and productivity.

### Weather compensation controls

The UK weather is changeable so heating controls that adjust to these unpredictable conditions can provide good savings. Weather compensation is a form of automatic control for heating systems. It reduces the water temperature in the heating system as the outside temperature increases. Installation costs will usually pay back their investment in just a couple of years.

The diagram (right) shows the interrelation between the thermostats, compensator and heating system. You can also refer to our [weather compensation controls animation](#).

Weather compensation controls automatically adjust heating circuit flow temperatures in accordance with the outside air temperature. It works by using a sensor outside the building and another connected to the boiler communicating with each other and varying the boiler's water flow temperature accordingly. This is more efficient than the boiler turning on and off, and energy is saved since flow temperature is reduced during milder weather.

External thermostat – set away from vents, obstructions, sun and open windows

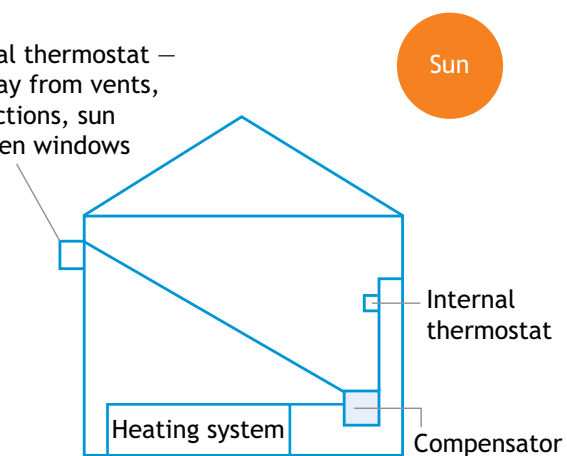

For smaller systems, a compensator can sometimes directly control the boiler. However, when heating floor areas of over 1,000m<sup>2</sup>, it is usually necessary to fit a weather compensator and motorised valve to vary the flow of heat to the building. Compensators can be combined with other energy saving features including optimum start, day economy and frost protection.

Consult a qualified heating technician to discuss the range of options available.

### Did you know?

When considering fitting weather compensation controls, it's worth looking at the Energy Efficiency Financing scheme brought to you by Carbon Trust Implementation and Siemens Financial Services. To find out more visit [www.energyefficiencyfinancing.co.uk](http://www.energyefficiencyfinancing.co.uk)

## Night setback

This reduces or 'sets back' space temperature during specific time periods, most commonly at night. Night setback is often provided as part of weather compensation controls and is mainly applicable to continuously occupied premises, for example, nursing homes or hotels.

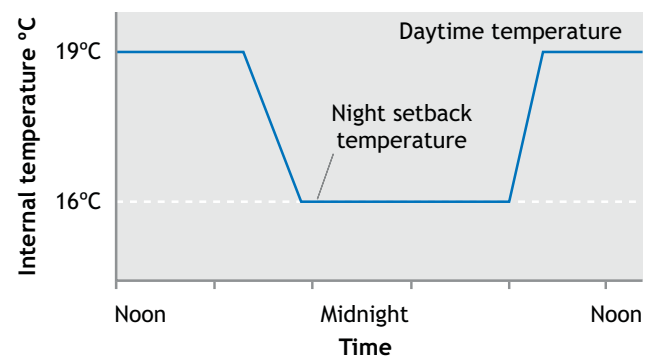

## Interlocked control for heating systems

Large open doors result in substantial heat losses. If heat is cut off when doors are opened, there is an incentive for people to keep doors closed. Simple interlock controls are relatively cheap to install and they will link the operation of heaters so that they switch off automatically when doors are opened in areas such as loading bays, garages and workshops.

## Automatically adjust heating to meet the reduced demand of unoccupied areas

Install a two-stage thermostat for more flexible control. These provide a setback temperature when an occupancy sensor detects that the room (for example at 15°C) is empty. When occupants return, the thermostat increases the level of heating to the required occupant temperature (for example, 20°C). Substantial savings can be achieved depending on building size and occupation patterns.

## Zoning

Consider the activities which take place in the building and take account of the heat gains from equipment, staff and sunshine. Just as it is possible to zone workspace according to operating hours, it is also possible to design a heating control system to allow for different temperature requirements. This can improve working conditions and achieve significant savings see 'zoning' on [page 16](#) for further information.

## Black-bulb thermostats for radiant heaters

Conventional thermostats are inappropriate for radiant heating systems so consider black-bulb thermostats for better control and, consequently, energy savings. Black-bulb sensors and thermostats are designed to measure radiant heat rather than air temperature. For this reason they are particularly suitable in areas where radiant heat is used such as in warehouses, factories or heated spaces with high volumes of air changes. Consult a heating technician or supplier of radiant heating equipment to discuss the range of options available.

# Specifying new systems and procurement

When refurbishing or putting in a new heating system, it pays to buy the most efficient equipment possible. Remember that day-to-day running costs may quickly outweigh any additional costs of installation and so the more efficient the system installed, the less expensive it will be to run.

When specifying new controls always:

- Select the most appropriate heating system for the building and business requirements
- Prioritise energy efficiency in the design and installation stages
- Implement and maintain good system controls
- Carry out effective commissioning and maintenance of the heating system once installed (this may be through a maintenance contractor).

Similarly, when replacing individual components, it pays to specify the highest efficiency levels within the budget constraints. For instance, the running costs of a motor or pump operating continuously can exceed its purchase price within just a few months. The additional expense of energy efficient equipment should be offset against the savings over the lifetime of running the equipment – in most cases, efficient equipment pays for itself within a few years.

We've produced a [Project Planning Tool](#) to assist you getting your project through to implementation.

## Advice about new controls

When a new heating plant or controls are installed, ensure that the contractor or supplier explains clearly how to set and use the new system. Over time, incorrectly set controls can lead to increased energy consumption. Keep a record of control settings and display these near to the controls themselves so that they can be returned to their optimum settings if altered.

If upgrading controls seems to be an appropriate solution, it may be a good time to consider improving heating systems or investing in a Building Energy Management System, discussed on the next page.

## Replacing boilers

If a boiler is more than 15 years old, or if it is showing signs of inefficient operation, it should be replaced. However, replacement is not as simple as noting the old boiler's rating and purchasing a new, more efficient model. To find the best solution, thoroughly review the building's heating demand and the business's needs, and check these against technical, financial and policy requirements. What is the current heating system used in the building? Unless a major refurbishment is planned, it may not be cost effective to replace the whole heating system, so the new boiler must be compatible with what is there already. It may be necessary to upgrade the heating controls of the system to get the best from the new boiler. Do not forget to account for these costs when considering the purchase price. When considering a boiler replacement, advice should be sought from a qualified building services engineer or heating technician.

For more information on replacing your boiler please refer to our [specific boilers and heat distribution](#) web pages.

## Building Energy Management Systems (BEMS or BMS)

Businesses spending more than £10,000 a year on energy that are considering a serious controls upgrade could benefit from investing in a Building Energy Management System (BEMS). This is a computer-based system which provides the facility to control any building service. Intelligent controllers, or 'outstations', monitor conditions throughout the building, and determine the operation of the plant such as boilers, pumps, fans, motors and lighting in response to changing conditions like time, temperature and light levels.

A system can begin with a single controller. As other controllers are added, these can be linked using a simple communication network, and a PC can be connected to this network to observe their performance and adjust settings. Access to various networks at remote geographic locations can be achieved through the use of modems, IT networks and the Internet. Many systems now make use of browsers, and so many aspects of their operation are intuitive to users.

### Advantages of BEMS

The main advantage of a BEMS installation is the ease with which users can review the performance of controls and conveniently make adjustments.

Other advantages include:

- Energy saving control functions which will reduce energy bills
- Close control of environmental conditions
- Data can be logged and archived for energy management purposes
- Rapid information on plant status
- Alarms can be automatically generated, and appropriate personnel alerted
- Identification of maintenance requirements, both planned and reactive (e.g. systems can record the number of hours that motors have run, or identify filters on air supply systems which have become blocked). This facility can be interfaced with computerised maintenance systems
- Password protection can be set up to allow different users to have different access rights to match their particular needs
- Ease of expansion.

## Energy Efficiency Financing

Investing in energy efficient equipment makes sound business and environmental sense, especially with the easy, affordable and flexible Energy Efficiency Financing scheme brought to you by Carbon Trust Implementation and Siemens Financial Services.

To find out more visit  
[www.energyefficiencyfinancing.co.uk](http://www.energyefficiencyfinancing.co.uk)

## Tax incentives

Enhanced Capital Allowances (ECAs) are a straightforward way for a business to improve its cash flow through accelerated tax relief. The ECA scheme for energy-saving technologies encourages businesses to invest in energy-saving plant or machinery specified on the Energy Technology List (ETL) which is managed by the Carbon Trust on behalf of Government.

The ECA scheme provides businesses with 100% first year tax relief on their qualifying capital expenditure. The ETL specifies the energy-saving technologies that are included in the ECA scheme. The scheme allows businesses to write off the whole cost of the equipment against taxable profits in the year of purchase. For further information please visit [www.carbontrust.co.uk/eca](http://www.carbontrust.co.uk/eca) or call the Carbon Trust on 0800 085 2005.

A BEMS offers closer control and monitoring of building services performance, including heating, ventilation, and lighting. These systems can be monitored via the computer screen in real time. Some or all of the functions described on the preceding pages can often be integrated into a single BEMS. For large and new buildings, this is particularly relevant and likely to offer an appropriate and cost-effective energy efficiency solution.

However, a BEMS is only as good as the operators who use it. Therefore it is essential that the staff who will be operating and maintaining the system are trained appropriately. All reputable BEMS suppliers encourage training as it is in their interest that the system works well. If installing a new BEMS, involve key staff at the beginning of the project and ensure that they are aware of what the system will do and how to keep it performing efficiently.

Used correctly, BEMS can reduce total energy costs by 10% and increase comfort so they are well worth considering.

For more information please refer to the Carbon Trust's [How to Implement a Building Energy Management System CTL149](#) guide.

### Basic BEMS arrangement

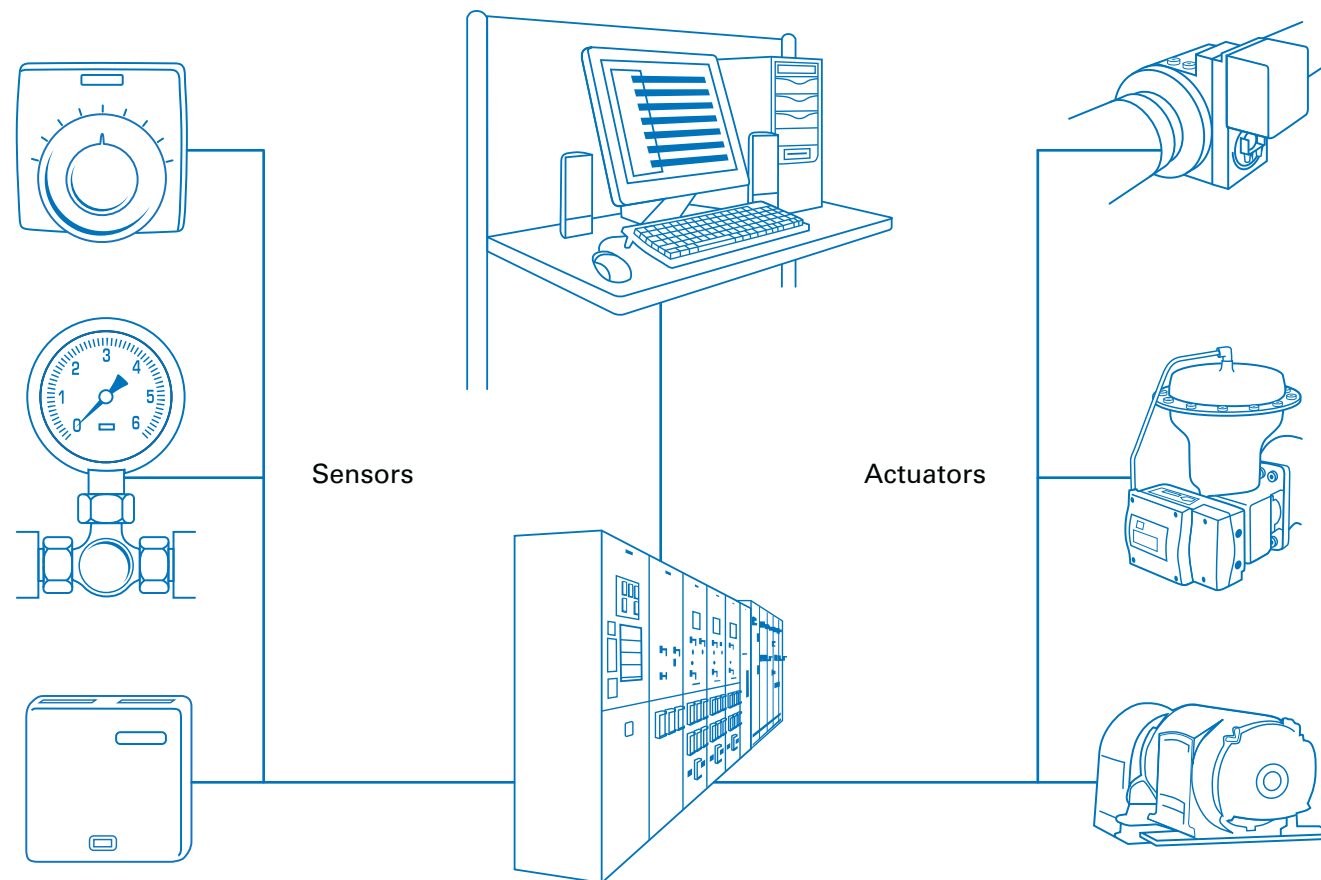

# Next steps

There are many easy low and no-cost options to help save money and improve the operation and control of your heating system.

## Step 1. Understand your energy use

Look at your heating controls and check the condition and operation of all pieces of equipment. Monitor the consumption of the building over, say, one week to obtain a base figure against which energy efficiency improvements can be measured.

## Step 2. Identify your opportunities

Compile an energy checklist. Walk round your building and complete the checklist at different times of day (including after hours) to identify where energy savings can be made. An example checklist is available on [page 27](#).

## Step 3. Prioritise your actions

Draw up an action plan detailing a schedule of improvements that need to be made and when, along with who will be responsible for them.

## Step 4. Seek specialist help

It may be possible to implement some energy saving measures in-house but others may require specialist assistance. Discuss the more complex or expensive options with a qualified technician.

## Step 5. Make the changes and measure the savings

Implement your energy saving actions and measure against original consumption figures. This will assist future management decisions regarding your energy priorities.

## Step 6. Continue to manage your business for energy efficiency

Enforce policies, systems and procedures to ensure that your business operates efficiently and that savings are maintained in the future.

# Glossary

## Boiler energy manager

Typically a device intended to improve boiler control using a selection of features such as weather compensation, load compensation, optimum start control, night setback, frost protection, anti-cycling control and hot water override.

## Boiler interlock

This is not a physical device but an arrangement of the system controls so as to ensure that the boiler does not fire when there is no demand for heat. In a system with a combination boiler, it can be achieved by fitting a room thermostat. In systems with other kinds of boilers, it can be achieved by correct wiring interconnections between the room thermostat, cylinder thermostat, and motorised valve(s). It may also be achieved by a suitable boiler energy manager.

## Boiler modulator (air temperature)

A device, or feature within a device, to vary the fuel burning rate of a boiler according to measured room temperature. The boiler under control must have modulating capability and a suitable interface for connection.

## Boiler modulator (water temperature)

A device, or feature within a device, to vary the fuel burning rate of a boiler according to measured water temperature. It is often fitted within the boiler casing. The boiler under control must have modulating capability.

## Boiler thermostat

A thermostat within the boiler casing to limit the temperature of water passing through the boiler by switching it off. The target temperature may either be fixed or set by the user.

## Cylinder thermostat

A sensing device to measure the temperature of the hot water cylinder and switch on and off the water heating. A single target temperature may be set by the user.

## Delayed start

A device, or feature within a device, to delay the chosen starting time for space heating according to the temperature measured inside or outside the building.

## Frost thermostat

A device to detect low air temperature and switch on heating to avoid frost damage, arranged to override other controls.

## Night setback

A feature of a room thermostat that allows a lower temperature to be maintained outside the period during which the normal room temperature is required.

## Optimum start

A device, or feature within a device, to adjust the starting time for space heating according to the temperature measured inside or outside the building, aiming to heat the building to the required temperature by a chosen time.

## Optimum stop

A device, or feature within a device, to adjust the stop time for space heating according to the temperature measured inside (and possibly outside) the building, aiming to prevent the required temperature of the building being maintained beyond a chosen time.

**Programmable room thermostat**

A combined time switch and room thermostat that allows the user to set different periods with different target temperatures for space heating, usually in a daily or weekly cycle.

**Programmer**

Two switches operated by a clock to control both space heating and hot water. The user chooses one or more 'on' periods, usually in a daily or weekly cycle. A mini-programmer allows space heating and hot water to be on together, or hot water alone, but not heating alone. A standard programmer uses the same time settings for space heating and hot water. A full programmer allows the time settings for space heating and hot water to be fully independent.

**Temperature and time zone control  
(or full zone control)**

A control scheme in which it is possible to select different temperatures at different times in two (or more) different zones.

**Time switch**

An electrical switch operated by a clock to control either space heating or hot water, or both together but not independently. The user chooses one or more 'on' periods, usually in a daily or weekly cycle.

**Thermostatic radiator valve**

A radiator valve with an air temperature sensor, used to control the heat output from the radiator by adjusting water flow.

**Wet system**

These systems typically use a boiler and pumps to transfer heated water to radiators.

**Weather compensator**

A device, or feature within a device, that adjusts the temperature of the water circulating through the heating system according to the temperature measured outside the building.

**Zone control**

A control scheme in which it is possible to select different times and/or temperatures in two (or more) different zones.

# Appendix

Start saving energy today. Whatever type of heating and controls are in place, the principles of reducing energy costs are essentially the same.

## Action checklist



To start saving energy and reducing your costs now, download and print our heating control action checklist.

 [Download](#)

---

## Go online to get more

The Carbon Trust provides a range of tools, services and information to help you implement energy and carbon saving measures, no matter what your level of experience.

---

**Call us on 0800 085 2005** – Our experts offer independent, authoritative advice. Lines open 8.30am-5.30pm, Monday to Friday.

---

**Website** – Visit us at [www.carbontrust.co.uk](http://www.carbontrust.co.uk) for our full range of advice and services.

---

**Publications** – We have a library of publications detailing energy saving techniques for a range of sectors and technologies.

➤ [www.carbontrust.co.uk/publications](http://www.carbontrust.co.uk/publications)

---

**Energy Saving Plan** – The Carbon Trust Advice Line can work with you to highlight areas for review within your organisation and can then provide you with a structured Energy Saving Plan. Call today on 0800 085 2005 and ask one of our advisors how an Energy Saving Plan could help your business save money and cut carbon.

---

**Cut Carbon, Cut Costs** – This tool gives you an introduction to energy saving and helps you create a personalised action plan for your site, estimating the cost and carbon savings you could make in your workplace.

➤ [www.carbontrust.co.uk/onlinetraining](http://www.carbontrust.co.uk/onlinetraining)

---

**Case studies** – Our case studies show that it's often easier and less expensive than you might think to bring about real change.

➤ [www.carbontrust.co.uk/casestudies](http://www.carbontrust.co.uk/casestudies)

---

**Energy Efficiency Financing** – Investing in energy efficient equipment makes sound business and environmental sense, especially with the easy, affordable and flexible Energy Efficiency Financing scheme brought to you by Carbon Trust Implementation and Siemens Financial Services. To find out more visit [www.energyefficiencyfinancing.co.uk](http://www.energyefficiencyfinancing.co.uk)

The Carbon Trust is a not-for-profit company with the mission to accelerate the move to a low carbon economy. We provide specialist support to business and the public sector to help cut carbon emissions, save energy and commercialise low carbon technologies. By stimulating low carbon action we contribute to key UK goals of lower carbon emissions, the development of low carbon businesses, increased energy security and associated jobs.

**We help to cut carbon emissions now by:**

- providing specialist advice and finance to help organisations cut carbon
- setting standards for carbon reduction.

**We reduce potential future carbon emissions by:**

- opening markets for low carbon technologies
- leading industry collaborations to commercialise technologies
- investing in early-stage low carbon companies.

**[www.carbontrust.co.uk](http://www.carbontrust.co.uk)**  
**0800 085 2005**

The Carbon Trust receives funding from Government including the Department of Energy and Climate Change, the Department for Transport, the Scottish Government, the Welsh Assembly Government and Invest Northern Ireland.

Whilst reasonable steps have been taken to ensure that the information contained within this publication is correct, the authors, the Carbon Trust, its agents, contractors and sub-contractors give no warranty and make no representation as to its accuracy and accept no liability for any errors or omissions. Any trademarks, service marks or logos used in this publication, and copyright in it, are the property of the Carbon Trust. Nothing in this publication shall be construed as granting any licence or right to use or reproduce any of the trademarks, service marks, logos, copyright or any proprietary information in any way without the Carbon Trust's prior written permission. The Carbon Trust enforces infringements of its intellectual property rights to the full extent permitted by law.

The Carbon Trust is a company limited by guarantee and registered in England and Wales under Company number 4190230 with its Registered Office at: 6th Floor, 5 New Street Square, London EC4A 3BF.

Published in the UK: October 2011.

© The Carbon Trust 2011. All rights reserved.

